

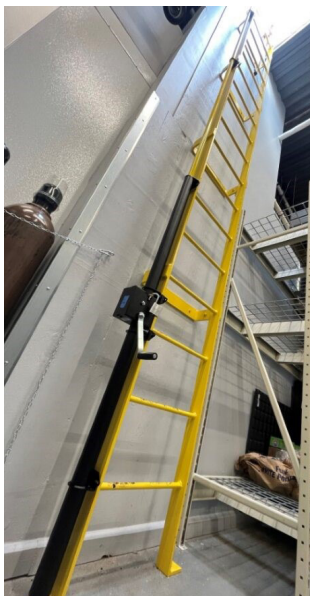

SAFEWAZE

Belmont Safety Hatch System Manual



023-12154	10' to 20' Belmont Safety Hatch System with Flat Brackets
023-12155	20' to 27' Belmont Safety Hatch System with Flat Brackets
023-12156	27' to 34' Belmont Safety Hatch System with Flat Brackets
023-12157	10' to 20' Belmont Safety Hatch System with Front Mount Brackets
023-12158	20' to 27' Belmont Safety Hatch System with Front Mount Brackets
023-12159	27' to 34' Belmont Safety Hatch System with Front Mount Brackets
023-12160	10' to 20' Belmont Safety Hatch System with Round Brackets
023-12161	20' to 27' Belmont Safety Hatch System with Round Brackets
023-12162	27' to 34' Belmont Safety Hatch System with Round Brackets

**Read and understand instructions before using equipment!
Do not throw away instructions!**

**Always verify the latest revision of the Safewaze Manual is being utilized.
Visit the Safewaze website, or contact Customer Service, for updated manuals.**

⚠️ IMPORTANT:

- Please refer to this manual for essential instructions on the use, care, or suitability of this equipment for your application. Contact Safewaze for any additional questions.
- Record all important product information prior to use. Documentation of all Competent Person annual inspections is required in the Inspection Log.

▶ USER INFORMATION

Date of First Use: _____

Serial Number: _____

Trainer: _____

User: _____

▶ SAFETY INFORMATION AND PRECAUTIONS

- The manufacturer's instructions must be provided to users of this equipment.
- The user must read, understand, and follow all safety and usage information contained within this manual.
- The user must safely and effectively use the Belmont Safety Hatch System and all equipment used in conjunction with the Belmont Safety Hatch System.
- Failure to follow all safety and usage information can result in serious injury or death.

⚠Warnings:

Regulations included herein are not all-inclusive, are for reference only, and are not intended to replace a Competent Person's judgment or knowledge of federal or state standards.

The warnings/notices indicated below are designed to minimize risk associated with the use of the Belmont Safety Hatch System and associated equipment:

- Women who are pregnant and individuals considered minors must not use any Safewaze equipment.
- Do not alter or misuse equipment. Only Safewaze, or entities authorized in writing by Safewaze, may make repairs to Safewaze equipment.
- A Competent Person must conduct an analysis of the workplace and anticipate where workers will be conducting their duties, the route they will take to reach their work, and any existing and potential fall hazards. The Competent Person must choose the fall protection equipment to be utilized. Selections must account for all potential hazardous workplace conditions. All fall protection equipment should be purchased in new and unused condition.
- Training of Authorized Persons to correctly install, inspect, disassemble, maintain, store, and use equipment must be provided by a Competent Person. Training must include the ability to recognize fall hazards, minimize the likelihood of fall hazards, and the correct use of personal fall arrest systems.
- System must be inspected prior to each use, and at least annually by a Competent Person other than the user. Annual inspections should be documented in the inspection grid on the label, as well as the instruction manual.
- The ladder to which this system is attached must be inspected in accordance with its individual inspection criteria.
- Clear hatch of all debris (ice/snow/etc.) before use.
- Only operate the system from the ground, do not operate while ladder and/or hatch is in use.
- Unlock system winch to raise or lower hatch.
- Maintain control of handle until winch system is locked to avoid the handle freewheeling backwards.
- Lock system prior to climbing and when not in use. Follow all appropriate climbing protocols.
- Fall protection gear is required for the installer.
- Lock out when done to prevent misuse.
- Don't stick any body part through roof hatch until fully open.
- Utilize safety pole when exiting or entering hatch.

TABLE OF CONTENTS

1.0 ▶ Introduction	5
2.0 ▶ Intended Use	5
3.0 ▶ Worker Classifications	5
4.0 ▶ Product Limitations/Specifications	6
5.0 ▶ Pre-Installation Instructions of BSHS	6
6.0 ▶ Installation of BSHS	10
7.0 ▶ Operation of BSHS	12
8.0 ▶ Inspection	13
9.0 ▶ Maintenance	16
10.0 ▶ Warranty	16
11.0 ▶ Label	17
15.0 ▶ Inspection Form	18

► 1.0 INTRODUCTION

Thank you for purchasing the Safewaze Belmont Safety Hatch System. This manual must be read and understood in its entirety and used as part of an employee training program as required by OSHA or any applicable state agency.

The Belmont Safety Hatch System is a bolt-on system that is designed to make roof access fast, efficient, and safe. When installed on a ladder and used correctly, the floor-level operating system allows the user to unlock and open a roof access hatch from the ground, greatly reducing the risk of climbing a ladder and opening a hatch simultaneously.

The system is sold in height ranges of 10' to 20', 20' to 27', and 27' to 34' with flat, front mount, or round bracket options. Prior to ordering, the user should check the intended ladder for installation and base their purchase on their specific ladder configuration needs. If assistance is needed, contact Customer Service at (800) 230-0319.

► 2.0 INTENDED USE

The equipment covered in this manual is intended for use as a roof access hatch-opening safety system. Use of this equipment for any other purpose including, but not limited to, sports or recreational activities, non-approved material handling applications, or other action not described in these instructions is not approved by Safewaze. Use of this equipment in a manner outside the scope of those covered within this manual can result in serious injury or death. The equipment covered in this manual must only be used by trained personnel in workplace applications.

► 3.0 WORKER CLASSIFICATIONS

Read and understand the definitions of those who work in proximity of, or may be exposed to, fall hazards:

Qualified Engineer: A person with a Bachelor of Science in Engineering degree from an accredited college or university. They are able to assume personal responsibility for the development and application of engineering science and knowledge in the design, construction, use, and maintenance of their projects.

Qualified Person: One who, by possession of a recognized degree, certificate, or professional standing, or who by extensive knowledge, training, and experience, has successfully demonstrated their ability to solve or resolve problems relating to the subject matter, the work, or the project.

Competent Person: One who is capable of identifying existing and predictable hazards in the surroundings or working conditions which are unsanitary, hazardous, or dangerous to employees, and who has authorization to take prompt corrective measures to eliminate them.

Authorized Person: A person approved or assigned by the employer to perform a specific type of duty or duties, or to be at a specific location or locations, at the jobsite.

It is the responsibility of a Qualified Person or Engineer to supervise the jobsite and ensure safety regulations are met.

▶ 4.0 PRODUCT LIMITATIONS/SPECIFICATIONS

When installing or using this equipment always refer to the following limitations and specifications:

- **System Capacity:** 600 lbs. (272.15 kg).
- **Hatch Dimensions:** 30" x 30" to 36" x 36"

	10' to 20'	20' to 27'	27' to 34'
Flat Brackets	023-12154 (41.0 lbs./18.6 kg)	023-12155 (47.4 lbs./21.5 kg)	023-12156 (53.7 lbs./24.4 kg)
Front Mount Brackets	023-12157 (43.6 lbs./19.8 kg)	023-12158 (50.8 lbs./23.0 kg)	023-12159 (57.9 lbs./26.3 kg)
Round Brackets	023-12160 (39.4 lbs./17.9 kg)	023-12161 (45.2 lbs./20.5 kg)	023-12162 (51.1 lbs./23.2 kg)

- **Hazards:** Extra precautions should be taken if this equipment is used in an environment where hazards exist. Hazards can include, but are not limited to, moving machinery, high voltage equipment or power lines, caustic chemicals, corrosive environments, toxic or explosive gases, or high heat.

Mounting Brackets	Powder Coated Steel
Lifting Tubes	Galvanized/Powder Coated Steel
Hatch Adapter Plate	Powder Coated Steel
Drive Unit	Galvanized/Powder Coated Steel
Bolts, Nuts, Washers	Zinc Plated Steel

▶ 5.0 PRE-INSTALLATION INSTRUCTIONS OF BELMONT SAFETY HATCH SYSTEM

Prior to purchasing a Belmont Safety Hatch System, evaluate the intended ladder's configuration to determine which system height and mounting brackets are needed. The BSHS works on standard-sized hatches from 30" x 30" to 36" x 36". Additionally, ensure the hinges of the roof hatch are in the proper location for installation (Figure 1). When opening the hatch, the hinges should be behind the user when they ascend the ladder in order for the system to work correctly. If the hatch is oversized, or the hinges are in front of the user or to either side, please contact Safewaze for a custom Belmont Safety Hatch System.

Read all instructions carefully before beginning the installation process. Ensure that all parts are present prior to installation. Ideally, two people should install the BSHS for a quicker and easier installation. The installation will take between 1 to 2 hours. Fall protection gear is required for the installers.

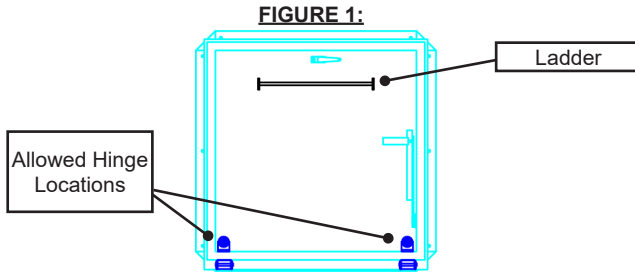

The final resting place of the Drive Unit Handle should be approximately 3.5 feet off the floor for ease of operating the handle. The Drive Unit will be between the third and fourth ladder rungs on an OSHA standard ladder. If installing on a nonstandard ladder, the installer can adjust the location of the Drive Unit as needed in order to ensure the top and bottom bracket locations are clear of the ladder rungs. The Drive Unit comes assembled with the Handle on one side but the Handle can be moved to the opposite side of its original install if needed. Contact Safewaze for instructions.

Clearance: The BSHS requires minimum clearances around the ladder in order to install and operate the system:

- **3"** of clearance needed for installation along the side of the ladder (Figure 2, A). Must be on the same side of the ladder that the Drive Unit will be installed.
- **3"** of clearance between the top of the ladder and the hatch curb (Figure 2, B). Must be on the same side of the ladder that the Drive Unit will be installed.
- **15"** of clearance at the side of the ladder to allow for the Drive Unit's Handle operation (Figure 2, C). Must be on the same side of the ladder that the Drive Unit will be installed. In its highest position, the Handle should be approximately 4' from the floor.

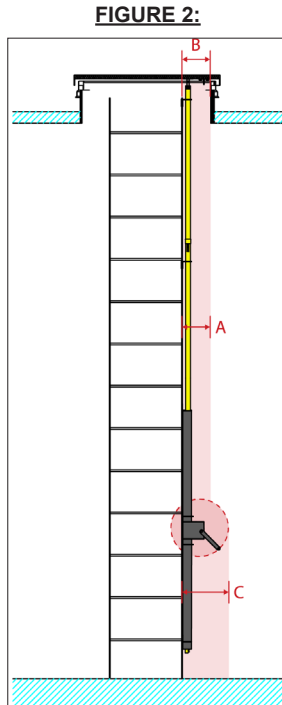

How to Measure/Cut to Size: The purchased kit includes the required amount of Lifting Tube Extensions for the desired installation height. The system poles are not telescoping poles. Therefore, a Lifting Tube Extension may need to be cut to size:

1. Measure the distance from the floor to the underside of the hatch (Figure 2, Measurement A).
2. Subtract Measurement A from the maximum height of the system purchased. The result is Measurement B (Figure 2, Measurement B).
3. Add 4" to Measurement B. The result is Measurement C. Measurement C should be between 0' and 6'.
 - If Measurement C is 0', all of the Lifting Tube Extensions included with the kit must be used, but no cutting is required.
 - If Measurement C is 6', 1 complete Lifting Tube Extension can be omitted from the assembly. No cutting is required.
 - If the result is other than above, Measurement C is the amount that must be cut off of 1 of the Lifting Tube Extensions.
4. If cutting to size is necessary, only the wide end of the tube can be cut (this end has a pre-drilled hole). Do not cut from the tapered end. When finished, use a #11 drill bit to drill a hole approximately 1 ¼" from the cut end to replace the pre-drilled hole that was removed. **Note: The rivet is included and is used to rivet the lifting tube extensions together during installation.**
5. With the Drive Unit installed so that the handle is 3.5' off the floor, the assembled Lifting Arm and Lifting Tube Extensions should measure from the shoulder of the Drive Unit to 2" below the underside of the roof hatch. The 2" gap is required to accommodate the Hatch Adapter and the Hatch Opener Arm. If necessary, adjust the mounting location of the Drive Unit (Section 6) to achieve the required 2" gap.

Note: If 023-12154, 023-12157, or 023-12160 is purchased and the intended ladder is less than 14', the user may need to cut to size the Lifting Tube instead of the Lifting Tube Extension (the included Lifting Tube Extension can be omitted due to the intended ladder's height. The user may need to cut to size the Lifting Tube instead).

FIGURE 3:

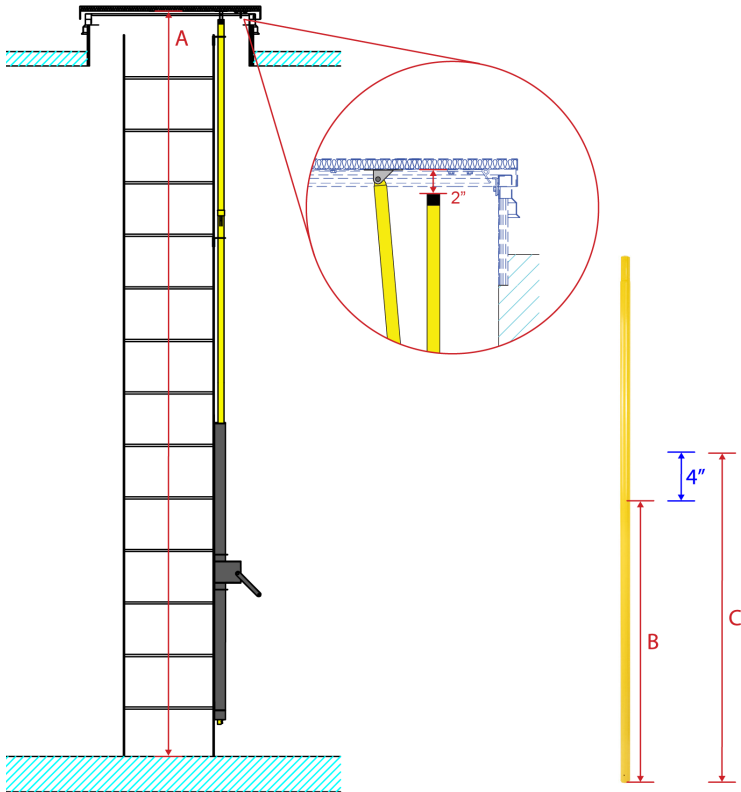

Example Calculation: The below example calculation is for the 20' to 27' Belmont Safety Hatch System with Square Brackets (Part Number: 023-12155).

1. The distance from the floor to the underside of the hatch is 24' (Figure 3, Measurement A).
2. Subtract Measurement A from the maximum height of the system. 023-12155 has a Maximum Height of 27'. The result is 3' (Figure 3, Measurement B).
3. Add 4" to measurement B. The result is 3' 4" (Figure 3, Measurement C).
4. Cut Measurement C off of the bottom (wide) end of 1 of the 2 included Lifting Tube Extensions.
5. With the Drive Unit installed so that the handle is 3.5' off the floor, the assembled Lifting Arm and Lifting Tube Extensions should measure from the shoulder of the Drive Unit to 2" below the underside of the roof hatch (Figure 3, Measurement C). If needed, adjust the position of the Drive Unit up or down slightly to achieve the 2" gap.

► 6.0 INSTALLATION OF BELMONT SAFETY HATCH SYSTEM

1. Position the Drive Unit so that its mounting holes are against the ladder. At this step, the bottom of the Drive Unit will be on the floor. Bolt the Drive Unit to the ladder at any two pairs of the four mounting hole options (Figure 4) using a Backing Plate, two Bolts, four Washers, and two Stop Nuts (Figure 5). Tighten bolts until the Drive Unit stays in place (0.75 ft.-lbs.), but do not over-tighten bolts at this step. If multiple lengths of bolts are included in the kit, choose the bolts with the least amount of excess length when installed.
2. Attach the Handle to the Drive Unit by sliding it through the already installed bolt, fix with a backing nut.
3. Place all remaining Guide Brackets on the tube at the top of the Drive Unit prior to next step. These will slide up the pole for installation later.
4. Evenly space out any remaining Guide Brackets along the Lifting Tube and attach with the backing plates. If installing with front mount brackets, the included shims in the purchased kit can be used for spacing if a flat bar is fixed to the outside of the ladder and is causing misalignment.
5. At this step, ensure that the roof hatch is closed. Identify the Lifting Tube*. Align the pre-drilled holes in the Lifting Tube and verify the flanges on the Lifting Tube are parallel with the ladder side (Figure 6). Connect the Lifting Tube to the Drive Unit with 1/8" Blind Rivets using the included rivet adapter and a drill.

*If installation requires an optional Lifting Tube Extension, insert the Extension into the bottom of the Lifting Tube.

6. Attach the Hatch Opener Arm to the Hatch Adapter using a Clevis and Cotter Pin combination.
7. Attach the Hatch Opener Arm to the Lifting Tube using a Clevis and Cotter Pin combination.
8. Use the Handle of the Drive Unit and raise the Hatch Opener Arm until the flat side of the Hatch Adapter is in full contact with the underside of the roof hatch.
9. Attach the Hatch Adapter to the underside of the roof hatch using the included Self-Tapping Screw in the pre-drilled holes of the Hatch Adapter. **Do not use alternative screws to attach the Hatch Adapter.** Use as many of the six holes as possible with the hatch closed. The rest can be done from the roof at the end of the installation.
10. Attach the Top Guide Bracket to the top of the ladder on the same side the Drive Unit is mounted, using a Backing Plate, two bolts, four washers, and two stop nuts. The top of the Guide Bracket should be 3"- 4" below the underside of the closed hatch.
11. To ensure the Drive Unit is at the correct height for maintaining the waterproof seal, close the roof hatch, loosen the bolts at the top and bottom of the Drive Unit, and allow the Drive Unit to settle into place. Turn the Drive Unit Handle counterclockwise 180° to release gears, then turn Handle clockwise until the Drive Unit raises itself off the floor. This will be the final height of the Drive Unit. Retighten the bolts to secure the Drive Unit in place.

12. Open hatch and lock hatch in fixed position before taking off the hatch hinges and lock receiver.
13. Lock the system from the Drive Unit (Section 7, Step 4) to keep hatch open. From the roof, remove the factory-installed lock receiver and handle from the roof hatch to prevent these mechanisms from inhibiting the operation of the BSHS System.
14. Close hatch with Drive Unit.

FIGURE 4:

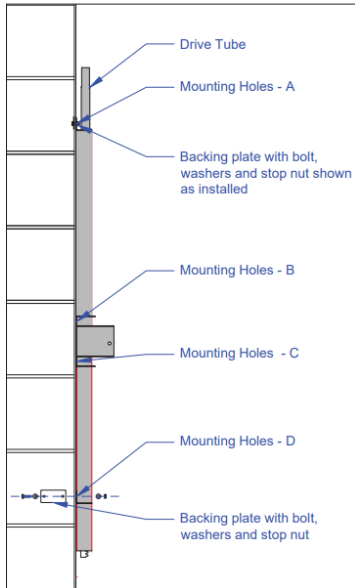

FIGURE 5:

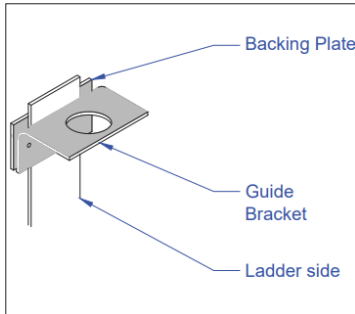
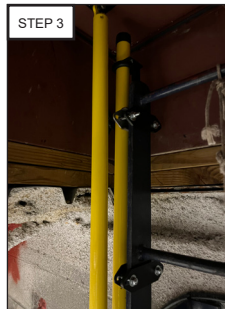
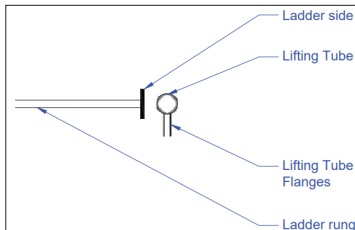
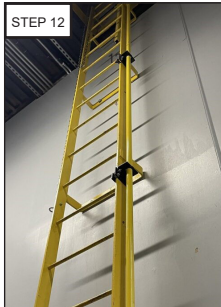
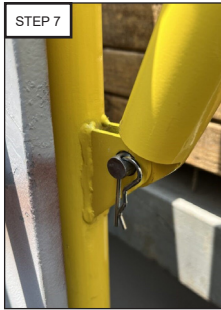

FIGURE 6:



Note: If using Flat Backing Plates, the threaded ends of the bolts should face away from the ladder (1) to ensure a clear climbing path. The **only exceptions** are the bolts on the lower attachment point of the extended top bracket (3). The threaded ends of these bolts should face the ladder so they do not interfere with the movement of the tubes when lifting the hatch.



► 7.0 OPERATION OF BELMONT SAFETY HATCH SYSTEM

1. The Drive Unit is in a locked position when the yellow tab of the lock bar is directly under the black tab. A padlock can be used to hold the system in a locked or unlocked position.
2. The system must be unlocked prior to opening the roof hatch. Unlock the system by moving the yellow tab to the right.
3. Crank the Drive Unit Handle counterclockwise to raise the Lifting Tube and open the roof hatch.
4. When the roof hatch is open, lock the system in the open position by moving the yellow tab of the lock bar back to the left until it's flush beneath the black tab. Insert the padlock through the two holes of the lock bar. **Locking the system prior to climbing the ladder is essential.** This ensures the user is not harmed by a falling hatch or locked outside should the hatch close due to an unlocked Drive Unit.
5. To lower the hatch, unlock the Drive Unit again by moving the yellow tab of the lock bar to the right.
6. Crank the Drive Unit Handle clockwise to lower the Lifting Tube and close the roof hatch.
7. Lock system when finished by moving the yellow tab of the lock bar to the left until it's flush with the black tab of the lock bar. Place padlock through the two holes of the lock bar to ensure it cannot be bumped and unlocked accidentally.

► 8.0 INSPECTION

The user must keep instructions available for reference and record the date of first use on Page 2.

The user must immediately remove the system from service if defects or damage are found.

Work Area:

- Inspect the work area to ensure the location is free of any damage including, but not limited to, debris, cracking, rot, decay, structural deterioration, rust, and any hazardous materials.
- Clear hatch of all debris (ice/snow/etc.) before use.
- A Competent Person must determine that the installation location to be utilized will support the intended loads.

Frequency:

- A Competent Person, other than the user, must inspect the Belmont Hatch Safety System at least once annually.
- While conducting inspections, the Competent Person must consider all applications and hazards that the equipment may have been subjected to while in use.
- Competent Person inspections must be recorded in the Inspection Log included in this manual (Page 17), as well as the inspection table labels on each product individually. The Competent Person must place their initials in the block which corresponds with the month and year that the inspection is performed. All individual labels on the equipment will be initialed in the same manner.

Directions:

- Prior to each use, inspect the BSHS for possible deficiencies including, but not limited to, missing parts, corrosion, deformation, pits, burrs, rough surfaces, sharp edges, cracking, rust, paint buildup, excessive heating, alteration, and missing or illegible labels.
- Prior to each use, the user must inspect and verify that **each individual component** of the system is safe for use:
 1. The handle must move freely and must not interfere with the ladder rungs or any other system component.
 2. Inspect the applicable brackets, housing, connectors, and fasteners.
 3. Inspect the ladder to which the system is mounted based on its manufacturer specifications.

Components Inspection:

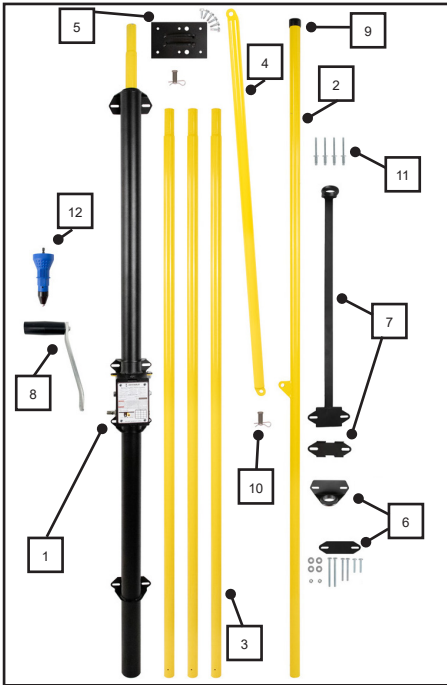

Flat Backing Plate Set Kits

1	Drive Unit
2	Lifting Tube
3	Lifting Tube Extension(s): <ul style="list-style-type: none"> • 023-12154 = 1 • 023-12155 = 2 • 023-12156 = 3
4	Hatch Opener Arm
5	Hatch Adapter with Self-Tapping Screws
6	Guide Brackets/Backing Plates: <ul style="list-style-type: none"> • 023-12154 = 2/6 • 023-12155 = 4/8 • 023-12156 = 6/10
7	Top Guide Bracket
8	Handle
9	Rubber Cap
10	Clevis/Cotter Pin (2)
11	Rivets: <ul style="list-style-type: none"> • 023-12154 = 4 • 023-12155 = 4 • 023-12156 = 4
12	Rivet Adapter

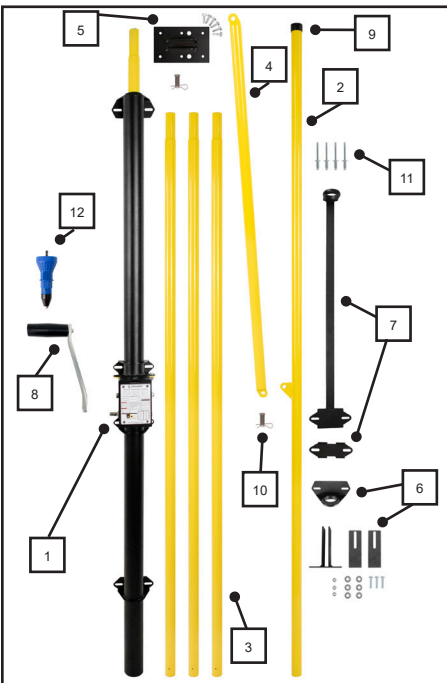

Front-mount Backing Plate Set Kits

1	Drive Unit
2	Lifting Tube
3	Lifting Tube Extension(s): <ul style="list-style-type: none"> • 023-12157 = 1 • 023-12158 = 2 • 023-12159 = 3
4	Hatch Opener Arm
5	Hatch Adapter with Self-Tapping Screws
6	Guide Brackets/Backing Plates: <ul style="list-style-type: none"> • 023-12157 = 2/6 • 023-12158 = 4/8 • 023-12159 = 6/10
7	Top Guide Bracket
8	Handle
9	Rubber Cap
10	Clevis/Cotter Pin (2)
11	Rivets: <ul style="list-style-type: none"> • 023-12157 = 4 • 023-12158 = 4 • 023-12159 = 4
12	Rivet Adapter

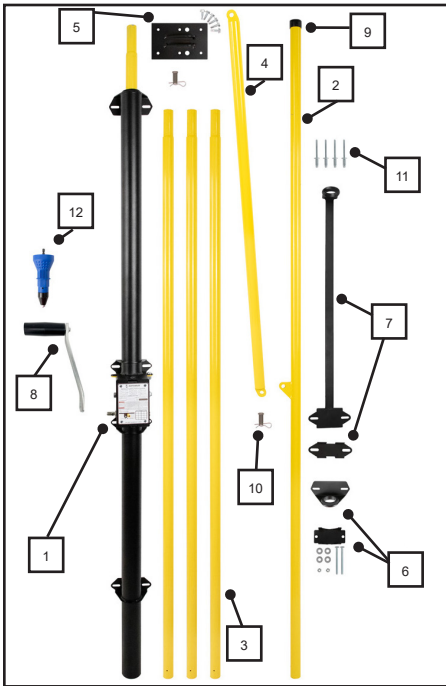

Round Backing Plate Set Kits

1	Drive Unit
2	Lifting Tube
3	Lifting Tube Extension(s): <ul style="list-style-type: none"> • 023-12160 = 1 • 023-12161 = 2 • 023-12162 = 3
4	Hatch Opener Arm
5	Hatch Adapter with Self-Tapping Screws
6	Guide Brackets/Backing Plates: <ul style="list-style-type: none"> • 023-12160 = 2/6 • 023-12161 = 4/8 • 023-12162 = 6/10
7	Top Guide Bracket
8	Handle
9	Rubber Cap
10	Clevis/Cotter Pin (2)
11	Rivets: <ul style="list-style-type: none"> • 023-12160 = 4 • 023-12161 = 4 • 023-12162 = 4
12	Rivet Adapter

Guide Brackets Inspection:

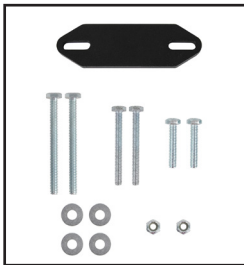

Flat Backing Plate Set (023-12163)

Components:

023-12154, 023-12155, 023-12156

1	Flat Backing Plate
2	Hardware Set: <ul style="list-style-type: none"> • Washers (4) • Nuts (2) • Short Bolt (2) • Medium Bolt (2) • Long Bolt (2)

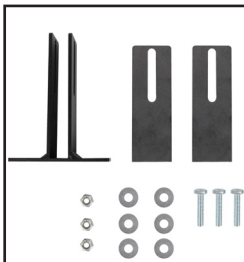

Front-mount Backing Plate Set (023-12164)

Components:

023-12157, 023-12158, 023-12159

1	Face Mount Backing Plate
2	Hardware Set: <ul style="list-style-type: none"> • Washers (6) • Nuts (3) • Short Bolt (3) • 1/8" Shim (2)



Round Backing Plate Set (023-12165)

Components:

023-12154, 023-12155, 023-12156

1	Round Backing Plate
2	Hardware Set: <ul style="list-style-type: none"> • Washers (4) • Nuts (2) • Long Bolt (2)

► 9.0 MAINTENANCE

Repairs:

Only Safewaze, or entities authorized in writing by Safewaze, may make repairs to Safewaze equipment.

Cleaning:

The BSHS can be cleaned with water and mild soap. The user should remove all dirt, grease, oil, possible corrosives, and contaminants from the system prior to, and after, each use. Never use any type of corrosive substance to clean the system.

Excess water should be blown out with compressed air. Hardware can be wiped off with a clean, dry cloth. Do not store system if wet or damp. Allow equipment to fully dry before being stored.

Storage:

Prior to installation, store the BSHS in a cool, dry area where it will not be exposed to extreme light, extreme heat, excessive moisture, or possibly corrosive chemicals or materials.

Lifespan:

The working life of the BSHS is determined by work conditions, care, and inspection provided. So long as the system and all components pass inspection, it may remain in service.

Disposal:

Dispose of the BSHS if inspection reveals an unsafe or defective condition. If damaged and unserviceable, the system should be uninstalled and disposed of to avoid accidental re-use.

► 10.0 WARRANTY

Safewaze warrants that all products are free from defects in materials and workmanship under normal use and service in accordance with manufacturer instructions. To utilize our warranty, simply contact Customer Service and arrange to return the product. Upon inspection, Safewaze will determine the appropriate course of action including certified repair, replacement with a new or comparable product, or credit of the purchase price. Safewaze is not liable for defects that are the result of product abuse, misuse, alteration or modification, or for defects that are due to a failure to install, maintain, or use the product in strict accordance with manufacturer instructions. No other warranty, express or implied, shall extend beyond the stated terms of this warranty.

▶ 11.0 LABEL



SAFEWAZE
www.safewaze.com

Belmont Safety Hatch System

023-12154
 023-12155
 023-12156

023-12157
 023-12158
 023-12159

023-12160
 023-12161
 023-12162

System Capacity: 600 lbs. (272.15 kg)

Installation Date: Serial #:

Installed By: DOM:

⚠ WARNING: Failure to heed warnings related to this system may result in serious injury or death. Manufacturer's instructions supplied with this product must be followed for proper installation, use, inspection, and maintenance of this equipment. Unauthorized alteration or substitution of components for this system is prohibited. System must be inspected prior to each use, and at least annually by a Competent Person other than the user. Annual inspections should be documented in the inspection grid on this label, as well as the instruction manual. The ladder to which this system is attached must also be inspected in accordance with its individual inspection criteria.

⚠ NOTICE: Clear hatch of all debris (ice/snow/etc.) before use. Only operate the system from the ground, do not operate while ladder and/or hatch is in use. Unlock system to raise or lower hatch. Maintain control of handle until system is locked. Lock system prior to climbing and when not in use. Follow all appropriate climbing protocols.

System Engagement



Lock ← → Unlock

	Initial	Date	Initial	Date

DO NOT REMOVE LABEL











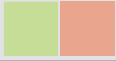

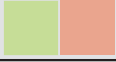

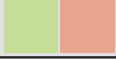

DO NOT REMOVE LABEL

Patent # US 11,293,229 B2 426-0001



SAFEWAZE

ANNUAL
INSPECTION
FORM

Inspection Date:	Inspector:	Pass/Fail: 	Comments/ Corrective Action:
			
			
			
			
			
			
			
			
			
			
			
			
			
			
			
			



SAFEWAZE

Address: 225 Wilshire Ave SW, Concord, NC 28025

Phone: 800-230-0319

Fax: 704-262-9051

Email: info@safewaze.com

Website: safewaze.com